

# Church Specialties, LLC

Joseph P. Duffy, III joe@churchspecialtiesllc.com • Christopher P. Duffy chris@churchspecialtiesllc.com  
 1-888- 570-1042 • P.O. Box 628, East Poultney, Vermont 05741 • Visit us online at [www.churchspecialtiesllc.com](http://www.churchspecialtiesllc.com)

## BELL SURVEY INSPECTION SHEET

Church: \_\_\_\_\_  
 Address: \_\_\_\_\_  
 City: \_\_\_\_\_ State: \_\_\_\_\_ Zip: \_\_\_\_\_  
 Contact Person: \_\_\_\_\_ Tel: \_\_\_\_\_  
 Email address: \_\_\_\_\_

***A photograph of the bell  
 would be helpful***

**If you have a Swinging Bell installation,  
 this is what should be checked:**

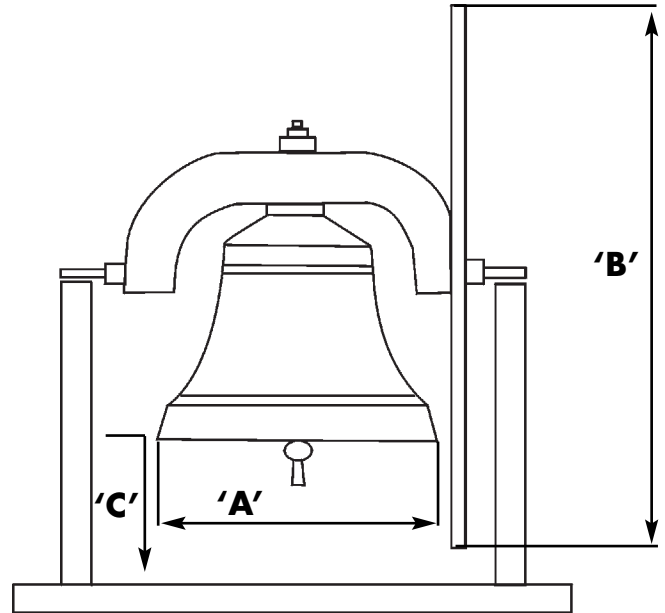
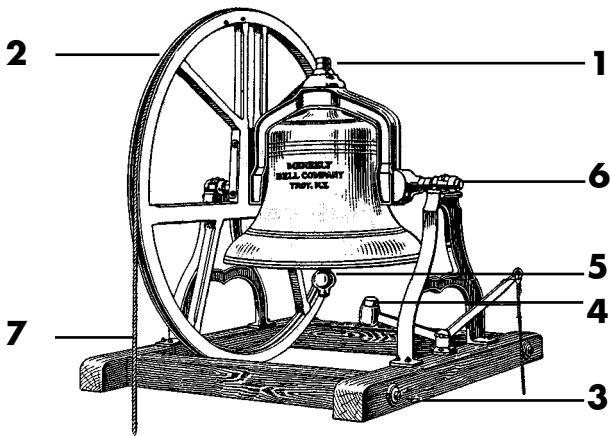

BELL: Foundry: \_\_\_\_\_

Date: \_\_\_\_\_

A. Diameter of Bell: \_\_\_\_\_

B. Diameter of Wheel: \_\_\_\_\_

C. Bottom of bell to  
 top of support beam: \_\_\_\_\_

- |   |  |         |                          |
|---|--|---------|--------------------------|
| 1. Bell loose in yoke.                  | Yes_____                               | No_____ | How many bolts _____     |
| 2. Wheel loose - pulling apart          | Yes_____                               | No_____ | Wood _____ Steel _____   |
| 3. Frame deteriorating                  | Yes_____                               | No_____ | Dimensions _____ x _____ |
| 4. Tolling hammer bent - loose fit      | Yes_____                               | No_____ |                          |
| 5. Clapper loose - spring leaves broken | Yes_____                               | No_____ |                          |
|   | Clapper Spring: Whole_____ Broken_____ |         |                          |
| 6. Axles worn and loose                 | Yes_____                               | No_____ |                          |
| 7. Rope rubbing on floor or projections | Yes_____                               | No_____ |                          |

General Comments: \_\_\_\_\_  
 \_\_\_\_\_  
 \_\_\_\_\_